

## [421] LAYING FLOOR COVERINGS WITH ELECTRICAL PROPERTIES, USING GTI EL5 CONTROL TILES WELDED WITH SKIRTING



**Ambient temperature**  
Minimum: 10° C



**Substrate temperature**  
Minimum: 10° C

Before laying the flooring, it is a good idea to inspect it and to identify any problems with the appearance. If there are visible defects, please notify GERFLOR and wait to hear from them before laying the flooring.

The laying procedure for GTI EL5 Control tiles starts with the uncut tiles and ends with the skirting

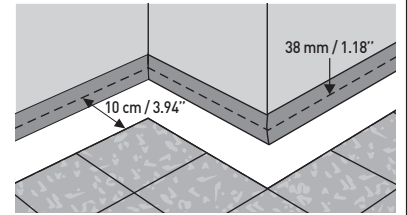

MATERIALS	FORMAT	CODE	NOTES
GTI EL5 CONTROL	650 X 650 / Th 6 mm	2714 followed by colour code	
GTI EL5 COVING CORNER OUT, cut at 45°	250 X 250	2721 followed by colour code	4 + 2 pieces
GTI EL5 COVING CORNER IN	250 X 250	2720 followed by colour code	6 pieces
GTI EL5 COVING	650 X 214	2719 followed by colour code	12 pieces
Copper strip	W (width) 10 mm / Th 0.08 mm	0586 0001	self tape copper strip is not permitted
Welding rod	100 ml	2722 followed by colour code	
Permanent adhesive or acrylic glue	Any make of acrylic glue		
Coving	38 mm	0480	

### ANTISTATIC ASTATIC FLOORINGS (ASF) < 2kW

Standard fitting. These floorings do not require any specific fitting method. (No copper strip required)

### DISSIPATIVE (DIF) AND CONDUCTIVE (ECF) FLOORINGS

Fitted using a permanent adhesive or acrylic glue only under the axis + copper strip: code 0586 0001 (length: 200 ml)  
Store the tiles for 24 hours in the room where they will be fitted.

#### REQUIREMENT SPECIFICATION FOR CONDUCTIVE FLOORINGS:

It is the responsibility of the client and/or contractor to set out the applicable standard in the requirement specification.

#### METHODS FOR RESILIENT FLOOR COVERINGS:

Europe: EN 1081. Transverse resistance and surface resistance on tripod

USA: ASTM F150/NFPA 99 (2 cylindrical electrode)

#### METHODS FOR ELECTRICAL INDUSTRIES:

Europe: CEI 61340-4-1

USA: ANSI/ESD S 7.1

For all other methods, see F Material technique

## 1. CHOICE OF JOINT TREATMENT

This material is laid edge to edge, **with or without** skirting.

FINISH	
	Joints hot welded with two-layer conductive seam + caulked at the edges (leave a 3 mm gap to apply mastic)
	Joints hot welded with two-layer conductive seam + skirting

See the section on FINISHES - "Joint treatments". \* Skirting must be installed after the flooring is laid.

# [421] LAYING FLOOR COVERINGS WITH ELECTRICAL PROPERTIES, USING GTI EL5 CONTROL TILES WELDED WITH SKIRTING

## 2. LAYING

**Preparation:** Moisture content 7% at 4 cm with a carbide bomb test.

### 2.1 - MARKING OUT AND LAYING THE STRIPS

- Mark out a line **around the room 10 cm** from the wall in all places, using a skirting scribe or a template on the wall
- **Do not use a chalk line as it will not follow the line of the wall**
- **Mark out the two perpendicular axes, making sure the cuts are the same on each side**
- Identify the copper strip and maintain it on the wall during the installation
- Use a roller to apply the permanent adhesive or acrylic glue evenly over the two axes with a coverage of about 100 to 150 g/m<sup>2</sup>
- Leave to set according to the manufacturer's instructions
- Lay one copper strip for **every 3 rows, in one direction**, holding it down with adhesive tape (see diagram)
- **Place a copper strip UNDER the cut tiles when you lay them**
- **Do not place the copper strip under the skirting tiles.**
- Leave some extra length at the end (about 50 cm) so it can pass under the skirting and the electrician can connect it to earth (one for every 40 m<sup>2</sup>)
- The copper strip can be located later with remote imaging

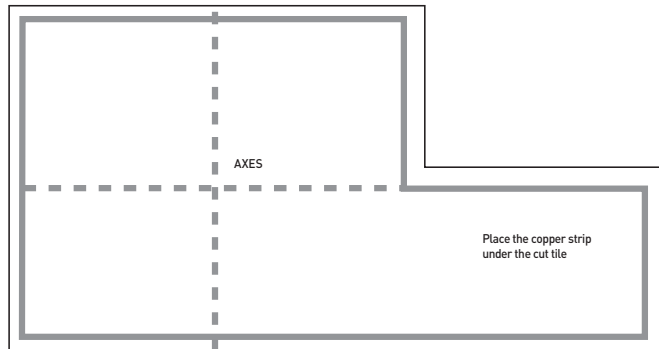

**Self tape copper strip is not permitted.**

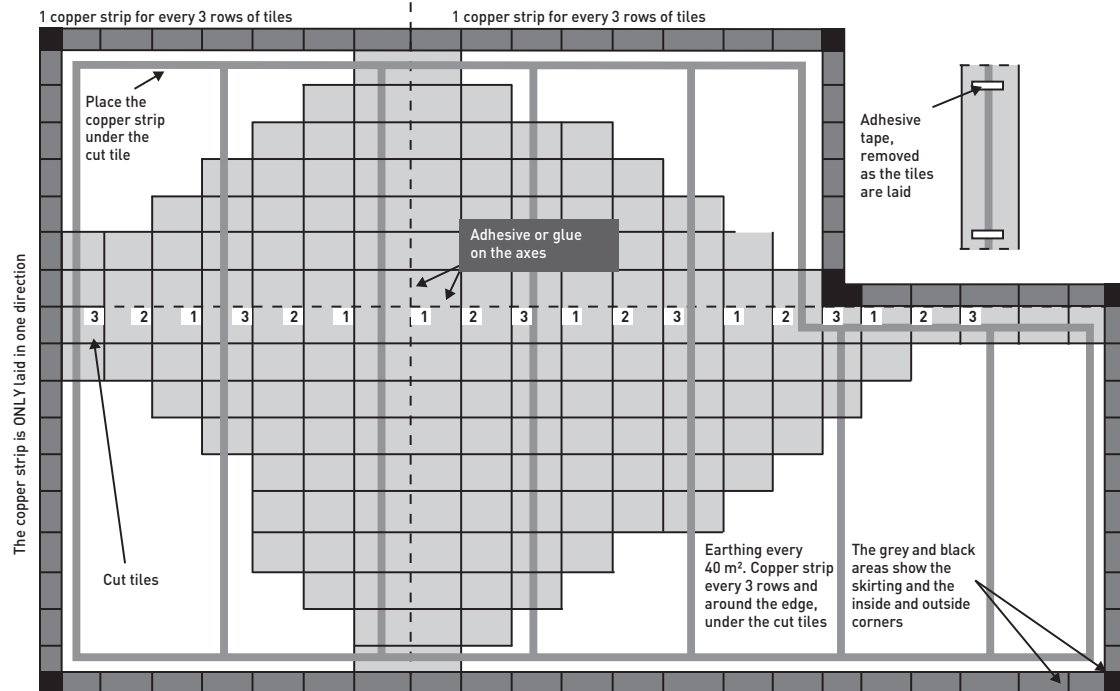

### 2.2 - LAYING THE UNCUT TILES

#### • Precautions

- 1- The tiles are supplied on pallets. Different batches must not be mixed together
- 2- Laying direction: Tiles are ALL laid in the same direction. Observe the direction indicated by the area on the back of the tile.
- 3- Pressed materials, such as GTI tiles, may have dimensional tolerances between series or between colours. In this case, the tiles can become slightly offset. Therefore, the entire row of tiles must be overlapped to continue laying. These two rows will be hot-welded.

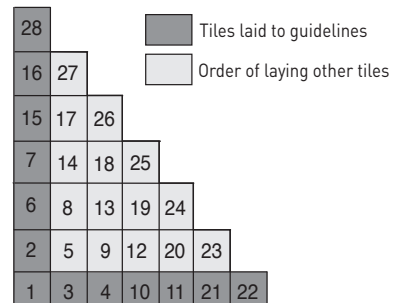
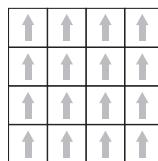

Lay the first tile and continue in a staircase pattern, following the axes you marked out. The tiles must be in contact with the substrate. Remove the adhesive tape from the strip as you work.

# FLOORS IN BUILDINGS

## [421] LAYING FLOOR COVERINGS WITH ELECTRICAL PROPERTIES, USING GTI EL5 CONTROL TILES WELDED WITH SKIRTING

### 2.3 - POSITIONING THE CUT TILES

The cut tiles must extend beyond the edging line you marked out.  
Mark out the edging line on the tiles using a skirting scriber or a template on the wall.

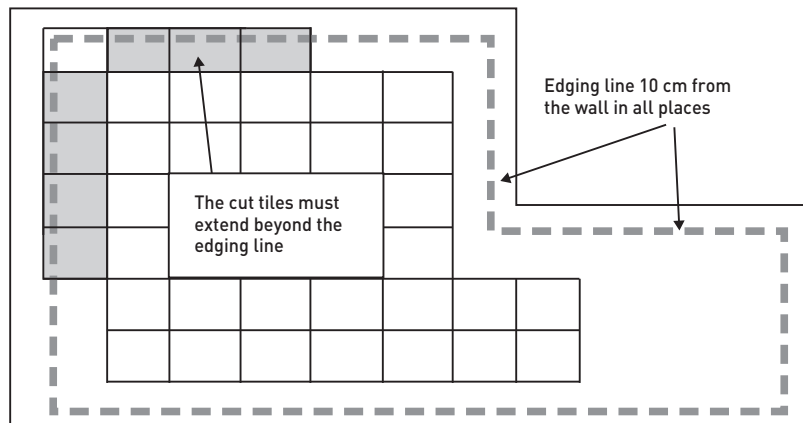

### 2.4 - EDGING THE CUT TILES

Use a cutter (make one marking cut and two surface cuts before snapping the tile).  
To help, you are recommended to heat the material with a hot-air paint stripper.  
This method means that no jigsaw is necessary.

The tiles must be cut by following the edging line marked out on the tiles, maintaining a distance of 10 cm in all places.

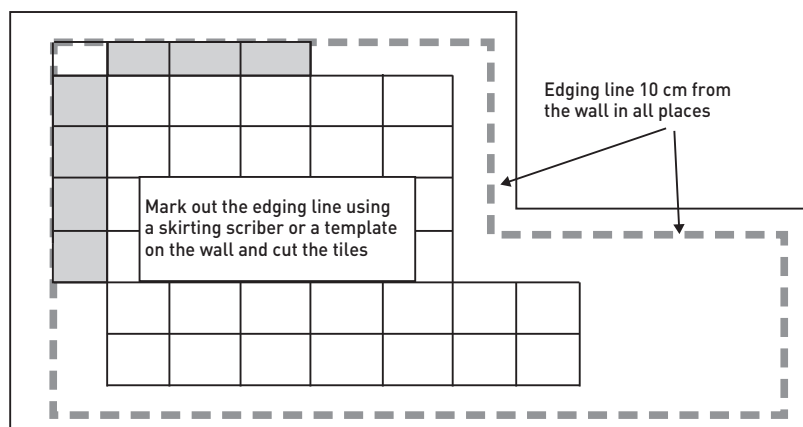

## 3. INSTALLING THE SKIRTING

If a clip-on finishing profile is provided to protect the edge of the skirting, mark out a line at 10 cm on the wall part and glue the base of the clip-on finishing profile.  
Position and glue on the 38 mm cove formers (cut the tabs in the corners).

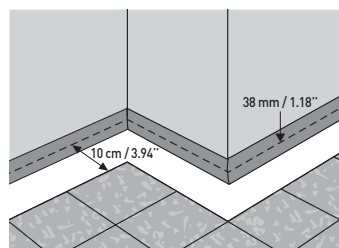

### 3.1 - FITTING THE INSIDE CORNERS

Use a solvent free contact adhesive for double gluing.  
Position the inside corners by cutting the tile at 45° on the vertical part. The cut must end in the middle of the cove former.

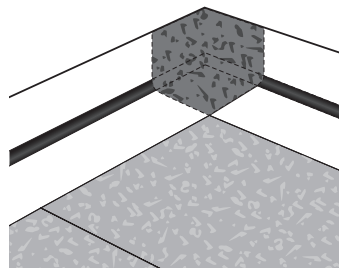

### 3.2 FITTING THE OUTSIDE CORNERS

There is a template on the packaging.  
Use the template to make the cut (2 per tile).  
Cut notches into the back to make the tiles easier to bend.  
Use a solvent free contact adhesive for double gluing.  
Position the triangles of the outside corners.

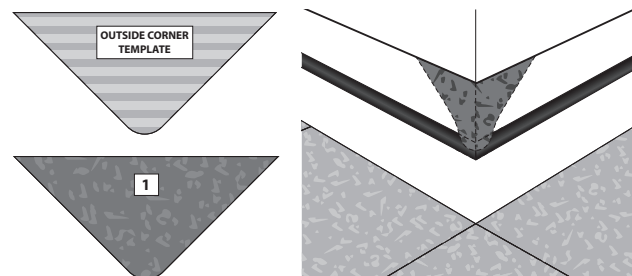

# [421] LAYING FLOOR COVERINGS WITH ELECTRICAL PROPERTIES, USING GTI EL5 CONTROL TILES WELDED WITH SKIRTING

## ■ 3.3 - FITTING THE COVER OF THE OUTSIDE CORNERS

Use a solvent free contact adhesive for double gluing.  
Position the corner covers using the corner of the edging tiles as the starting point.  
Scribe (cut) the cover around the triangle.

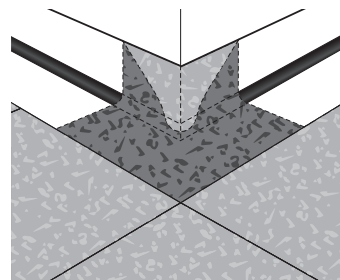

## ■ 3.4 - FITTING THE GTI EL SKIRTING

Use a solvent free contact adhesive for double gluing.  
Always start laying the skirting from the centre of each side. Align the skirting with the joints of the flat tiles.  
If necessary, cut the GTI EL skirting tiles to fill the spaces between the uncut tiles and the (inside and outside) corner pieces.

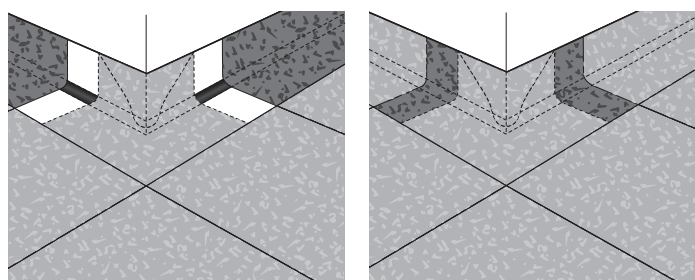

## 4. HOT WELDED JOINTS

### START BY WELDING THE SKIRTING

The tile joints are welded with a two-layer conductive seam.  
The two-layer conductive seam leaves a black thread after levelling.  
This thread provides conductivity between each tile.

#### IMPORTANT:

- The tiles are not supplied chamfered, but bevelled as a guide for the chamfering tool
- The removed two-layer conductive seam may leave marks on the flooring. You are recommended to collect the removed pieces as you work
- To prevent poor welds where the tiles intersect, it is necessary to chamfer, weld and level in one direction before repeating in the other direction

### ■ 4.1 WELDING THE SKIRTING

- **Chamfer the joints** with the triangular grooving tool and the cutter for corners

#### GTI EL Connect chamfering

Width: 3.3 to 3.5 mm  
Depth: 1.5 to 1.8 mm

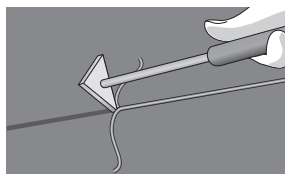
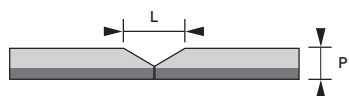

- **Hot weld the joints** using a Triac S hot air tool  
Use a hooked Rapid Ultra nozzle.  
Clean the nozzles regularly to prevent the formation of deposits along the seam.

We recommend the hooked Rapid Ultra nozzle:  
Janser code 224 800 013 or ROMUS code 95028

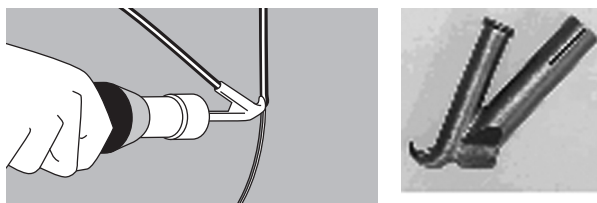

- **Level the seam** using a special skirting tool after the seam has cooled down.  
Do not leave the cut seam on the ground. Collect it as you work so it does not mark the flooring.

We recommend a tool that has been specially designed for skirting:  
Gerflor code 0562 0001

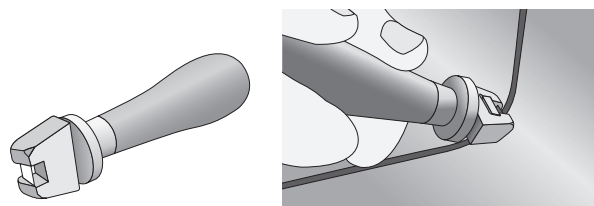

# FLOORS IN BUILDINGS

## [421] LAYING FLOOR COVERINGS WITH ELECTRICAL PROPERTIES, USING GTI EL5 CONTROL TILES WELDED WITH SKIRTING

### ■ 4.2 - FLAT WELDING

- **Chamfer the joints** using an electric chamfering machine, blade width 3.3 mm, depth 1.5 to 1.8 mm.

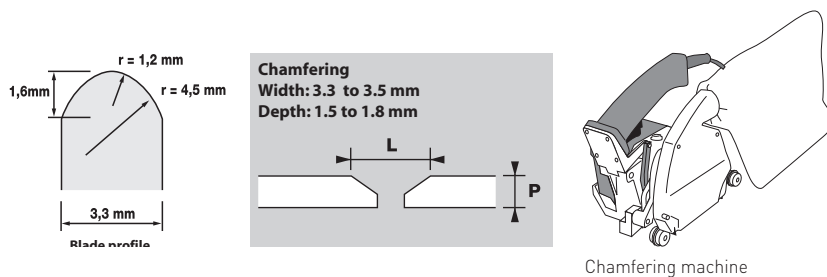

- **Hot weld the joints** using a welding machine. Use a LEISTER UNIVERSAL or UNIFLOOR hot air welding machine with electronically controlled heating, fitted with a narrow multi-outlet nozzle designed for this purpose.

TOOLS	ROMUS CODE	JANSER CODE	LEISTER CODE
Narrow nozzle	95254	225 860 040	105 407

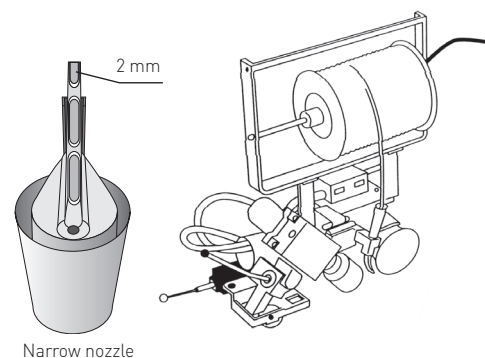

### ■ 4.3 LEVELLING THE SEAM

- Using a MOZART knife:
  - First pass:** make an initial cut by placing the levelling guide under the MOZART knife blade (fig. 1)
  - Second pass:** leave the seam to cool down completely
  - Rotate the levelling guide to 90° on the side to completely remove the excess seam material (fig. 2)

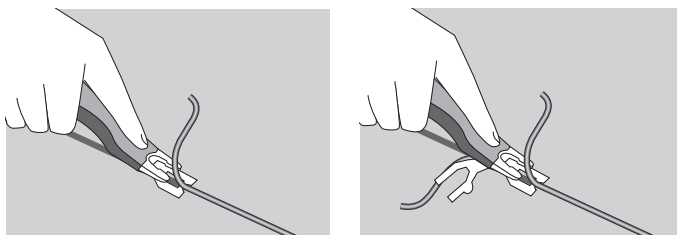

Fig. 1 - Levelling guide under the blade      Fig. 2 - Levelling guide at 90°

TOOLS	GERFLOR CODE
MOZART knife	0561 0001
Spare blades	0542 0001

**This method prevents hollow welds.**

- Level the seam in two passes after the seam has cooled down.

### ■ 4.4 JOINING OR REPAIRING WELDS

To prevent carbon black build-up during repairs:

- Make an initial levelling cut of the seam
- Clean the joint with a vacuum cleaner to remove the particles and run a triangular scraper over it
- Make a notch at both ends of the seam
- Use a hot air tool with the Rapid nozzle as explained above, starting and ending at the existing welds (about 5 cm).

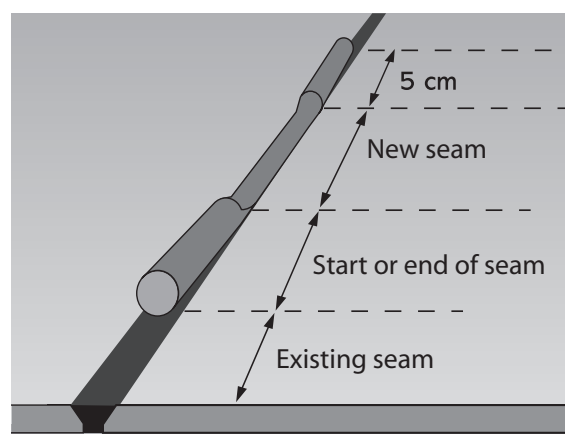

# [421] LAYING FLOOR COVERINGS WITH ELECTRICAL PROPERTIES, USING GTI EL5 CONTROL TILES WELDED WITH SKIRTING

## 5. CORNERS AND DOORWAYS

### 5.1 - ENDS AND DOORWAYS

Use the following profiles depending on conditions of use: traffic, humidity, etc.

#### 5.1.1 Heavy traffic, pallet trucks...

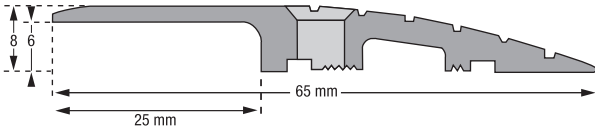

Finishing profile H 0505

#### 5.1.2 Moderate traffic

GTI EL5 CONTROL ACCESS AND CORNER		
GTI EL5 CONTROL ACCESS	635 x 320 mm	Code : 2715 followed by colour code
GTI EL5 CONTROL CORNER	320 x 320 mm	Code : 2716 followed by colour code

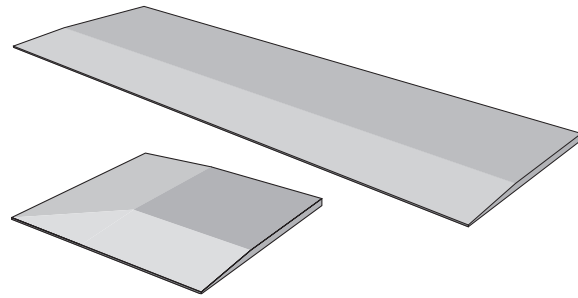

**These accessories must be glued down, either using a 2 components PU adhesive and weighted until the adhesive sets (6 to 12 hours), or using an acrylic double bonding adhesive.**

## 6. FIRST USE

- For normal traffic, the floor can be walked on immediately after welding.
- To move furniture, lay panels to distribute the load.
- Do not allow rubber feet to be used on furniture.

## 7. UNDERFLOOR HEATING

Underfloor heating should be turned up gradually over the seven days after the flooring is laid.

## 8. MAINTENANCE

### FINAL CLEANING

The floor covering can be used as soon as it is laid, but take these precautions:

- Deposits or scuffing remains from the seam
- Dampen a clean cloth with alkaline detergent and gently rub to clean the marks
- Then wipe with a sponge dampened with clean water

### DO NOT ATTEMPT TO CLEAN BY HAND OR USING A DRY CLOTH

After the marks are removed, flooring must be cleaned as follows:

- Remove dust and particles using a broom or an industrial vacuum cleaner
- Clean the floor with a scrubber drier using an alkaline detergent
- Rinse with clean water to remove all traces of the detergent
- Leave to dry

### DAILY CARE

Refer to the care sheet for the product.